



DX 76-MX DX 76-PTR

Quick Start Guide – Supplement



SAFETY FIRST		3
TOOL ANATOMY	DX 76-MX	4
	DX 76-PTR	5
SELECTING THE RIGHT NAIL, TOOL & CARTRIDGE		6
FASTENING METAL DECK TO THE STEEL STRUCTURE	INSTALLING THE DECKING NAIL	7-8
KNOWING HOW TO CLEAN THE TOOL		9-10
KNOWING ESSENTIAL FIELD TROUBLE SHOOTING	POSSIBLE CAUSES CARTRIDGES	11
	POSSIBLE CAUSES NAILS	12

Additional resources available are:

- Tool Operating Instructions
- How to video (use the resources in Hilti online or Hilti channel in YouTube)

**1****Requirements to be met by the user**

The tool is intended for professional use. The tool may be operated, serviced and maintained only by trained, authorized personnel who have received special instruction regarding the hazards that may be encountered.

Use the tool for the first time only after you have been trained by a Hilti specialist on how to use it safely.

2**Personal Protective Equipment (PPE)**



Operator and bystanders must wear helmet, eye and ear protection. Hilti recommends the operator wear hand gloves. In addition, all the jobsite safety requirements (steel toe safety shoes, safety harness, high visibility vest, etc.), deemed necessary by the local regulations and jobsite requirements must be adhered to.

**3****Personal safety**



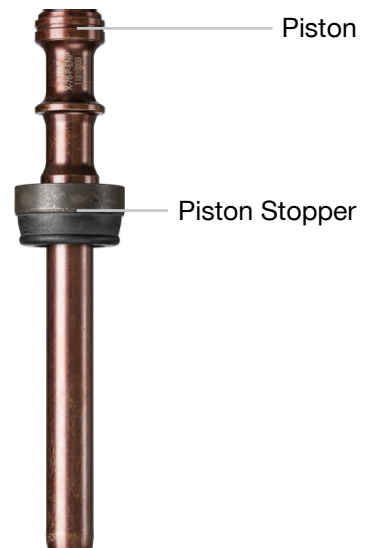

- Never tamper with or modify the tool in any way.
- Do not use the tool for purposes for which it was not intended.
- Stay alert, watch what you are doing and use common sense when operating the tool.
Do not use the tool if you are not concentrating.
- To reduce the risk of injury use only genuine Hilti accessories and spare parts or those of equivalent quality.
- Use only fasteners of a type approved for use with the tool.
- Observe the information printed in the operating instructions concerning operation, care and maintenance.
- Never point the tool toward yourself or other persons.
- Never press the nosepiece of the tool against your hand or against any other part of your body (or other persons hand or part of their body).
- Drive the fasteners only into structural steel members. Do not attempt to drive fasteners into other materials or into hardened or brittle steel, cast iron or spring steel.
- Pull the trigger only when the nosepiece of the tool is in contact with the working surface and the tool is fully compressed.
- When driving fasteners, always hold the fastening tool at right angles to the working surface in order to help prevent the fastener being deflected by the surface.
- Never redrive a fastener, as this may cause the fastener to brake.
- Keep the grips dry, clean and free from oil and grease.
- Never leave a loaded tool unattended.
- Always remove the cartridges before cleaning, servicing or carrying out maintenance work on the tool.
- Never leave the tool unattended.
- When not in use, the tool should be unloaded (cartridge strips removed) and stored in a locked, dry place where it is inaccessible to children.
- Never compress the tool while operating the Pawl, as this presents a risk of injury to the operators hand.
- Remove the cartridge strip from the tool carefully. Never attempt to pry a cartridge from the magazine strip or tool.
- Do not disassemble the tool while it is hot. If this is unavoidable, wear protective gloves.
- Store unused cartridges in a dry place, where they are locked away or high up and out of reach of children.
- Do not operate the tool when parts are damaged or when the controls do not function correctly, have the tool repaired by Hilti Tool Service.

Information here is general: read the operating instructions for complete details

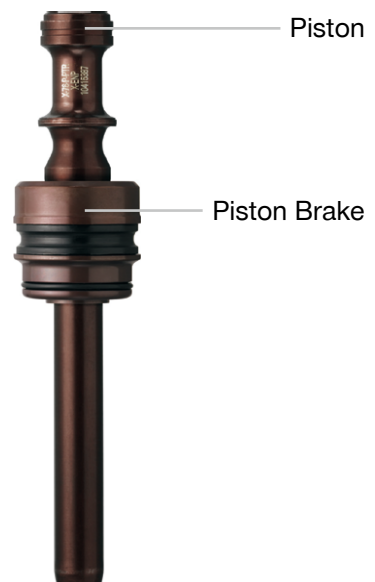

Piston	Fastener
 <p>X-76-P-ENP assembly</p>	 <p>X-ENP-19</p>



Piston	Fastener
 <p>X-76-P-ENP-PTR assembly</p>	 <p>X-ENP-19</p>
 <p>X-76-P-ENP2K-PTR assembly</p>	 <p>X-ENP2K-20</p>

Selecting the right nail, tool and cartridge is a pre-requisite for good quality fastening. In addition, improper selection can lead to excessive wear on the DX 76 deck fastening tool.

1 X-ENP2K-20

Select the right nail

X-ENP2K-20 L15 MX fastener is used for fastening deck into steel structures and light gauge steel in the thickness range 5/32" (4 mm) to 15/64" (6 mm).



1 X-ENP-19

Select the right nail

X-ENP-19 L15 MX fastener is used for fastening deck to structural steel 1/4"(6.4 mm) to full steel.



2 DX 76-PTR

Select the right tool & piston

DX 76-PTR tool can be used when punching through the deck is a concern, use X-76-P-ENP2K-PTR piston.



2 DX 76-MX & PTR

Select the right tool & piston

DX 76-MX tool is used for most applications and markets. DX 76-PTR tool can be used when punching through the deck is a concern.



See below reference chart to select the right color cartridge based on steel strength and steel thickness by nail type. The number within the box provides a quick reference for the tool power level. However, due to variability in base steel, check the nail stand-off by performing test fastenings and adjust the power level accordingly.

3 X-ENP2K-20

Select the right cartridge

For the X-ENP2K-20 nail you need to use the 6.8/18 M10 cartridge.

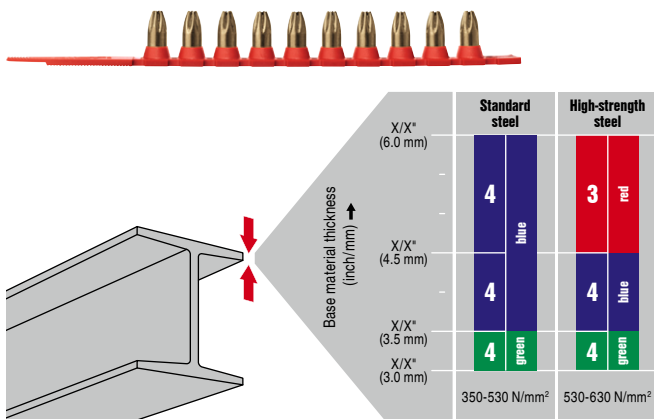

3 X-ENP-19

Select the right cartridge

For the X-ENP-19 L15 MX nail you need to use the 6.8/18 M10 cartridge.

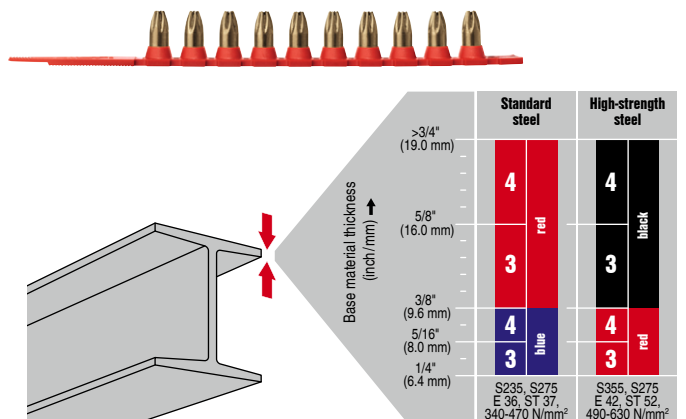

1
Mark the deck

Marking the deck is important to fasten on the joist or beam because you can't see the joist or beam when fastening the deck.

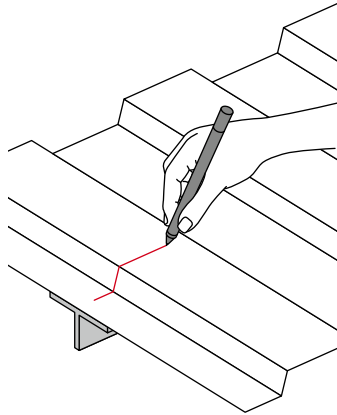

2
Load the nail

It is a good practice to always keep the Nail Magazine full. This reduces damage to the Piston Brake/Stop and subsequent damage to the Nail Detection Mechanism
Tip: For DX 76-MX/PTR load 1 nail strip first and then always load nails when cartridge strip runs out.

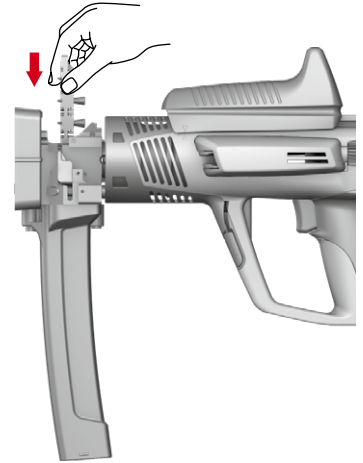

3
Load the cartridge



4
Check cartridge strip is flush

This step prevents missing the first cartridge on the strip.

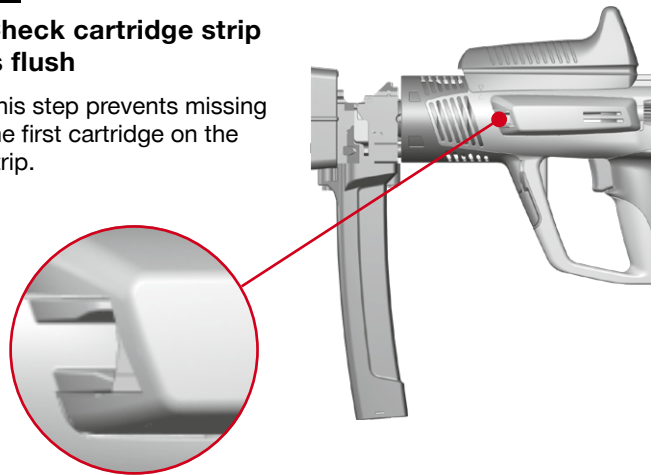

5
Align tool with the deck marking

Align the tool with the marking prior to fastening. Piston jam is a reported problem by our customers. In most cases is due to missing the joist or beam and gaps between the sheets or structural beams while making the fastening. Missing the joist and beam at the time of fastening can reduce the lifetime of the Piston and Piston Brake/Stop. Hence, it is important to mark the deck and align the tool with the mark while fastening.

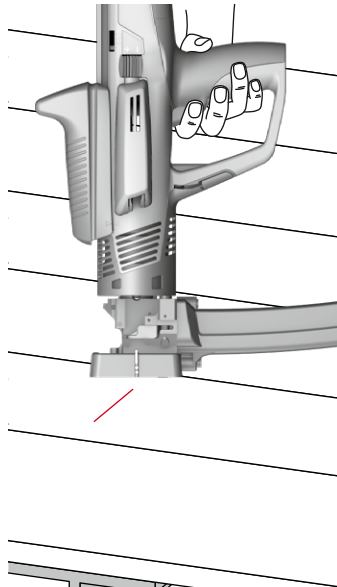

6
Compress the tool and pull the trigger

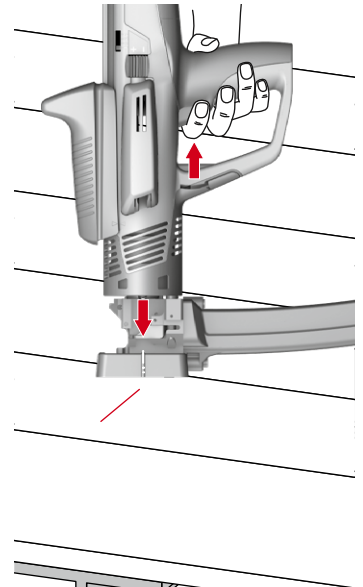

7 X-ENP2K-20

Check nail stand-off and adjust power level if required

Initially, then periodically while fastening, and any time you change base material, use the Power Adjustment Gauge to check the nail stand-off and adjust the tool power level.

7.1 X-ENP2K-20

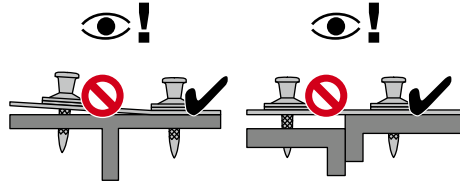

7.2 X-ENP2K-20

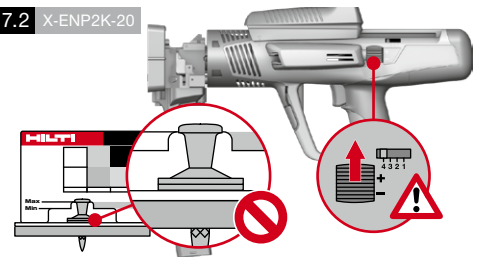

7.3 X-ENP2K-20

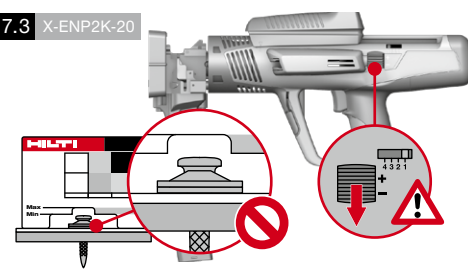

7.4 X-ENP2K-20

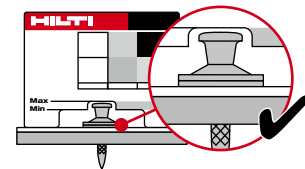

7 X-ENP-19

Check nail stand-off and adjust power level if required

Initially, then periodically while fastening, and any time you change base material, use the Power Adjustment Gauge to check the nail stand-off and adjust the tool power level.

7.1 X-ENP-19

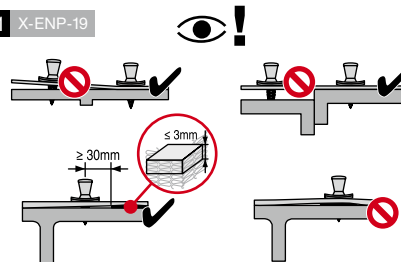

7.2 X-ENP-19

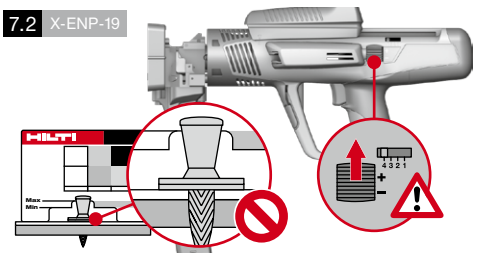

7.3 X-ENP-19

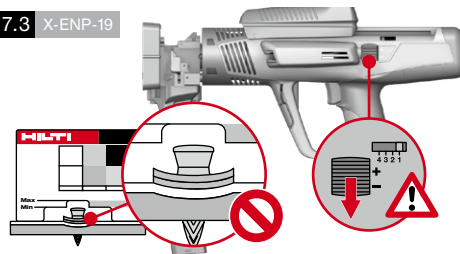

7.4 X-ENP-19

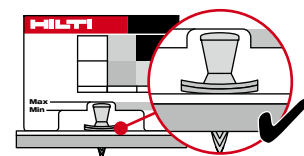

1
Disassemble the tool

Remove the cartridge strip and nails before disassembling the tool.

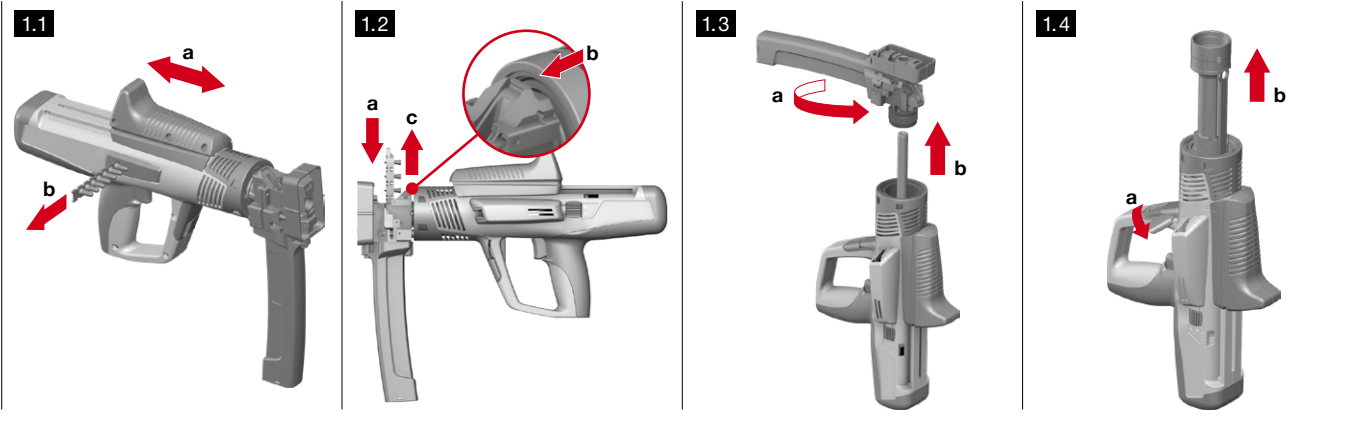

2
Clean the tool

While cleaning the tool, the Hilti spray should be applied ONLY on the Nail Magazine and NOT inside the tool.

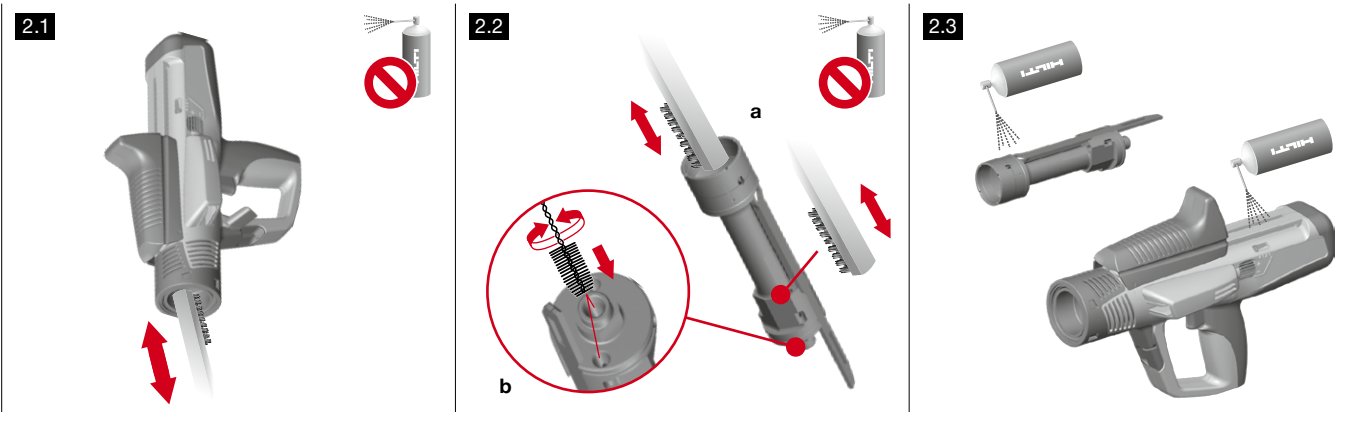

3 DX 76-MX
Check the Piston and Piston Stopper

Change if either the Piston or Piston Stopper is worn. Change only as a set both Piston and Piston Stopper.

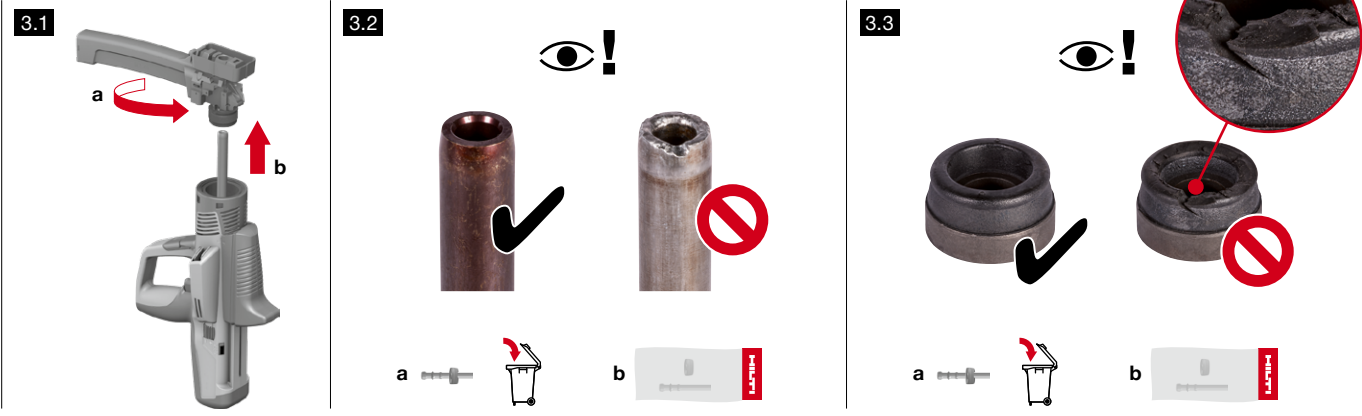

3 DX 76-PTR

Check the Piston and Piston Brake

Change if either the Piston or Piston Brake is worn. Change only as a set both Piston and Piston Brake.

3.1

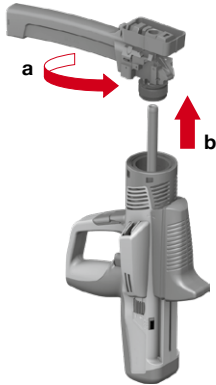

3.2



3.3



4

Assemble the tool

Check the Piston Brake/Stop and Piston is always assembled back in.

4.1

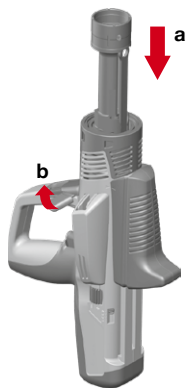

4.2

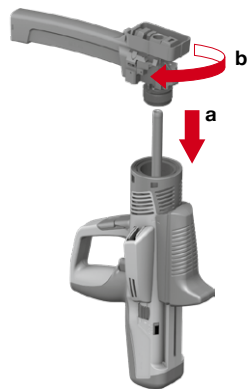

4.3

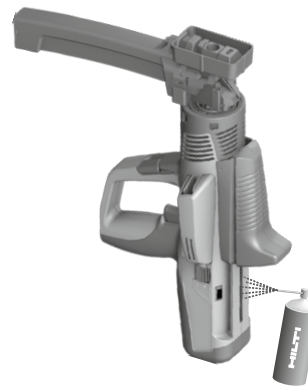



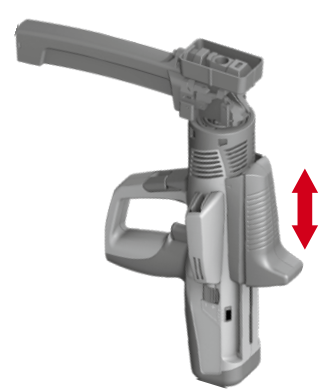

4.4







There are few instances the tool ceases to function on the jobsite. We identify below problems the customer may encounter, their possible causes and the recommended actions. Tool lifetime can be extended and higher tool performance can be achieved when the tool is cleaned and checked at regular intervals.

Problem	Possible causes	Recommended action
Cartridges are not transported	The cartridge strip is damaged	Change the cartridge strip
	The tool is damaged	Send DX 76 Tool to Hilti Tool Service Center
Cartridge Strip can't be removed	The tool is damaged or has overheated as a result of an excessively high fastener driving rate	Allow tool to cool, then carefully try to remove the cartridge strip. Remove the piston guide from the tool, if cartridge sleeve remains jammed in the chamber, use the round rod from the cleaning set to remove it – if not possible, contact Hilti
Cartridge doesn't fire  If a cartridge fails to fire or misfires, always proceed as follows: Keep the nose of the tool pressed at right angles against the working surface for 30 seconds. If the cartridge still fails to fire, lift the tool away from the working surface, taking care to avoid pointing it at yourself or other persons. Load the next cartridge on the strip by cycling the tool. Use up the remaining cartridges on the strip and remove the used cartridge strip from the tool. The (partly) used cartridge strip must then be disposed of suitably in order to prevent further use or misuse of any unfired cartridges.	The tool is not fully pressed against the working surface	Press the tool fully against the working surface and pull the trigger
	The cartridge strip is used up	Remove the used cartridge strip, load a new strip
	The magazine or fastener guide is not screwed on far enough	Screw the magazine farther onto the tool
	One of the cartridges is faulty	Cycle the tool and use up the remaining cartridges
	The tool is defective or the cartridges are faulty	Contact Hilti
	The tool is not cycled	Cycle the tool – section cleaning the piston guide
The tool remains compressed (doesn't extend when pressure is released)	The piston sticks in the piston stopper/brake	Change the piston and piston stopper/brake
	The tool is dirty	Clean the piston guide, check the straightness of the piston
	The cartridge strip has jammed, the tool has overheated	Please refer to the fault: "cartridge strip can't be removed". Do not exceed the maximum recommended fastener driving rate
The tool can't be fired	The tool wasn't cycled correctly, the cycling grip is not in the starting position	Cycle the tool fully against the working surface and then pull the trigger
	The trigger is pulled before the tool is pressed fully against the working surface	Press the tool fully against the working surface and then pull the trigger
	Fastener transport malfunctions	Loading fastener strips in the magazine and removing fastener strips from the tool – See page 9
	The magazine or fastener guide is not screwed on far enough	Screw the magazine farther onto the tool
	The tool is damaged	Contact Hilti
	The tool is badly fouled with dirt and residues	Clean the piston guide, check the straightness of the piston
Stiff cycling action	The tool needs to be cleaned	See page 9

X-ENP-19

Issue	Visual	Criteria	Trouble	Possible cause	Action
Nail stand-off too high		No piston mark visible, nail head stays off, stand-off too high	Deck is not fastened properly to the beam	Power setting too low or cartridge not strong enough	Dial up power setting or increase strength of cartridge
Nail stand-off is OK		Washer compressed, piston mark clearly visible, deck flat – no deformation	-	-	-
Nail stand-off is too low		Washer over compressed, deck deformed, stand-off too low	Deck is not fastened properly to the beam	Power setting too high or cartridge is too strong	Dial down power setting or decrease strength of cartridge
Gap between deck profile and beam		Nail stand off OK or too low without piston clear mark	Deck profile does not lay solid on the beam	Gap caused by slope of the deck or local effects	Avoid gap between sheet and beam or fasten at the right side of the beam
Beam miss		Nail stand off OK or too low, sheet metal one sided deformed (edge of the beam visible)	Beam miss	Deck not marked	Mark the deck

X-ENP2K-20

Issue	Visual	Criteria	Trouble	Possible cause	Action
Nail stand-off too high		No piston mark visible, nail head stays off, stand-off too high	Deck is not fastened properly to the beam	Power setting too low or cartridge not strong enough	Dial up power setting or increase strength of cartridge
Nail stand-off is too low		Washer compressed, piston mark clearly visible	Deck is not fastened properly to the beam	Power setting too high or cartridge is too strong	Dial down power setting or decrease strength of cartridge
Nail stand-off is OK		Washer compressed, piston mark slightly visible, deck flat – no deformation	-	-	-
Gap between deck profile and beam		Nail stand off OK or too low, deck slightly deformed	Deck profile does not lay solid on the beam	Gap caused by slope of the deck or local effects	Avoid gap between sheet and beam or fasten at the right side of the beam
Beam miss		Nail stand off OK or too low, sheet metal one sided deformed (edge of the beam visible)	Beam miss	Deck not marked	Mark the deck