

# КВД60/300 (E)

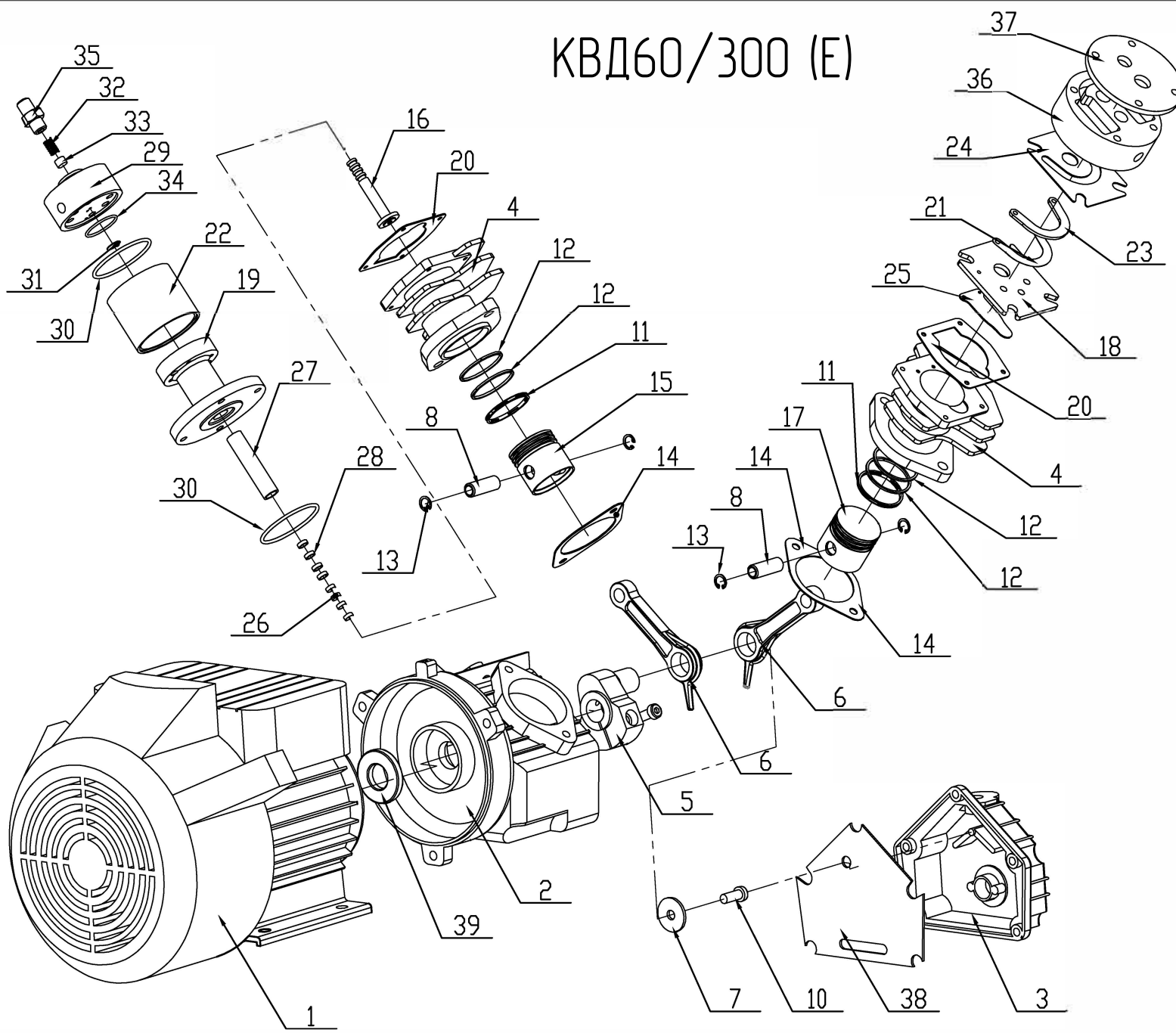

№п/п	Название	Прим.
1	electric motor	1
2	crankcase	1
3	front cover	1
4	1st stage cylinder	2
5	crank	1
6	connect rod	2
7	crank pad	1
8	piston pin	2
11	oil ring	2
12	piston ring	4
13	snap ring	4
14	crankcase gasket	2
15	guide piston	1
16	2nd stage piston	1
17	1st stage piston	1
18	1st stage valve plate	1
19	2nd stage cylinder	1
20	cylinder gasket	2
21	1st discharge valve	1
22	2nd stage water cylinder	1
23	hight limiter	1
24	valve gasket	1
25	1st intake valve	1
26	spring ring	4
27	2nd internal cylinder	1
28	2nd stage piston ring	4
29	2nd stage cylinder head	1
30	o ring	2
31	2nd intake valve	1
32	2nd discharge spring	1
33	2nd discharge valve	1
34	seal ring	1
35	2nd stage outlet fitting	1
36	1st stage cylinder head	1
37	1st stage cylinder cover	1
38	oil resist dlaphragm	1
39	oil sealer	1
		1