

Пневмопистолет FROSP ST64 по легкому бетону, кирпичу

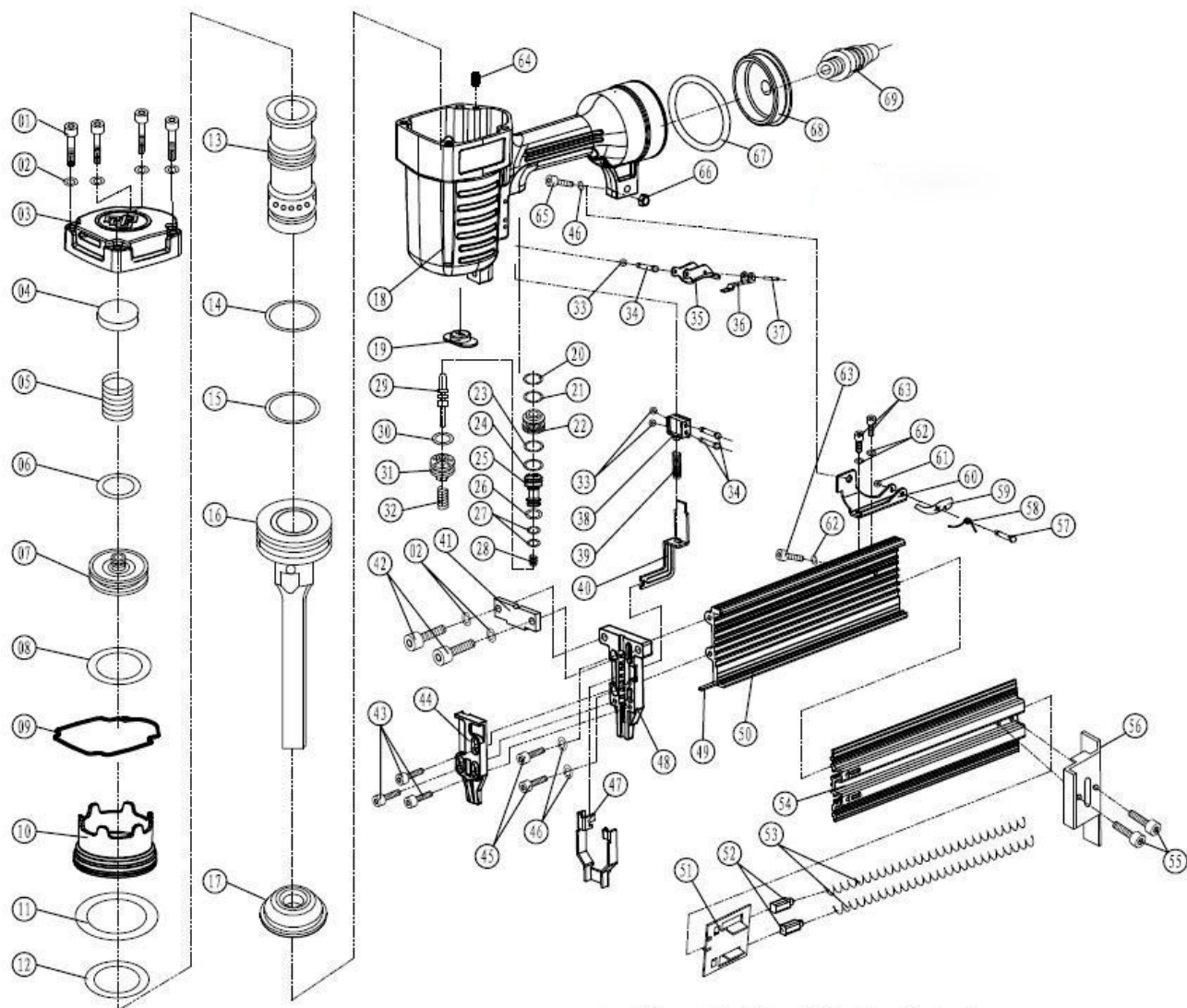

No.	K3 CODE	Description	Qty.	No.	K3 CODE	Description	Qty.	No.	K3 CODE	Description	Qty.
1	03.04.05.049	Bolt M6*35	4	24	03.04.01.048	O-ring 6.4*2	1	47	03.04.04.111-01	Safety nose	1
2	03.04.05.265	Spring Washer	6	25	03.04.29.005	Valve sleeve	1	48	03.04.08.157-01	Driver guide	1
3	03.04.28.086-02	Cylinder cover	1	26	03.04.01.060	O-ring 9*1.8	1	49	03.04.30.018	Insert bar	1
4	03.04.19.167	Sealing washer	1	27	03.04.01.034	O-ring 2.5*1.5	1	50	03.04.14.095	Fixed magazine	1
5	03.04.36.123	Compressed spring	1	28	03.04.34.043	Switch spring	2	51	03.04.09.035	Pusher	1
6	03.04.01.075	O-ring 13.7*2.4	1	29	03.04.15.038	Switch pole	1	52	03.04.15.107-01	Push rod	2
7	03.04.39.08.010	Head Valve	1	30	03.04.01.091	O-ring 18*2.65	1	53	03.04.36.135	Compressed spring	2
8	03.04.01.187	O-ring 56*2.65	1	31	03.04.32.056	Switch seat	1	54	03.04.18.055-02	Movable magazine	1
9	03.04.19.135	Sealing washer	1	32	03.04.36.006	Compressed spring	1	55	03.04.05.013	Bolt M4*16	2
10	03.04.19.136	Collar	1	33	03.04.01.027	O-ring 1.7*2	3	56	03.04.12.017-01	Locating seat	1
11	03.04.01.212	O-ring 73*2.65	1	34	03.04.31.056	Trigger pin	3	57	03.04.31.033-02	Shaft pin	1
12	03.04.01.185	O-ring 53*2.65	1	35	03.04.03.044-03	Trigger	1	58	03.04.24.051	Torsional spring	1
13	03.04.27.059	Cylinder	1	36	03.04.02.015	Safety spacer	1	59	03.04.10.030-01	Locating stem	1
14	03.04.01.183	O-ring 53*2	1	37	03.04.05.191	Pin 3*16	1	60	03.04.12.134-01	Fixed seat	1
15	03.04.01.166	O-ring 44.4*2.5	1	38	03.04.32.121-02	Safety seat	1	61	03.04.01.028	O-ring 1.9*1.1	1
16	03.04.39.01.066	Piston assembly	1	39	03.04.36.016	Compressed spring	1	62	03.04.05.262-03	Spring washer 4	3
17	03.04.06.053	Bumper	1	40	03.04.16.050-01	Safety yoke	1	63	03.04.05.009	Bolt M4*8	3
18	03.04.26.191-01	Gun body	1	41	03.04.02.065-01	Plate	1	64	03.04.05.204	Pin 4*10	1
19	03.04.06.009	Rubber washer	1	42	03.04.05.048	Bolt M6*30	2	65	03.04.05.034	Bolt M5*25	1
20	03.04.01.080	O-ring 15*2.65	1	43	03.04.05.028	Bolt M5*12	3	66	03.04.05.163-01	Nut M5	1
21	03.04.01.082	O-ring 16*1.6	1	44	03.04.13.154-01	Cover board	1	67	03.04.01.201	O-ring 63*2.65	1
22	03.04.32.105	Valve seat	1	45	03.04.05.032	Bolt M5*20	2	68	03.04.11.011-10	End cap	1
23	03.04.01.047	O-ring 6.1*1.8	1	46	03.04.05.263-03	Spring washer	3	69		Air inlet plug	1