

Детализировка и лист запасных частей FROSP F50

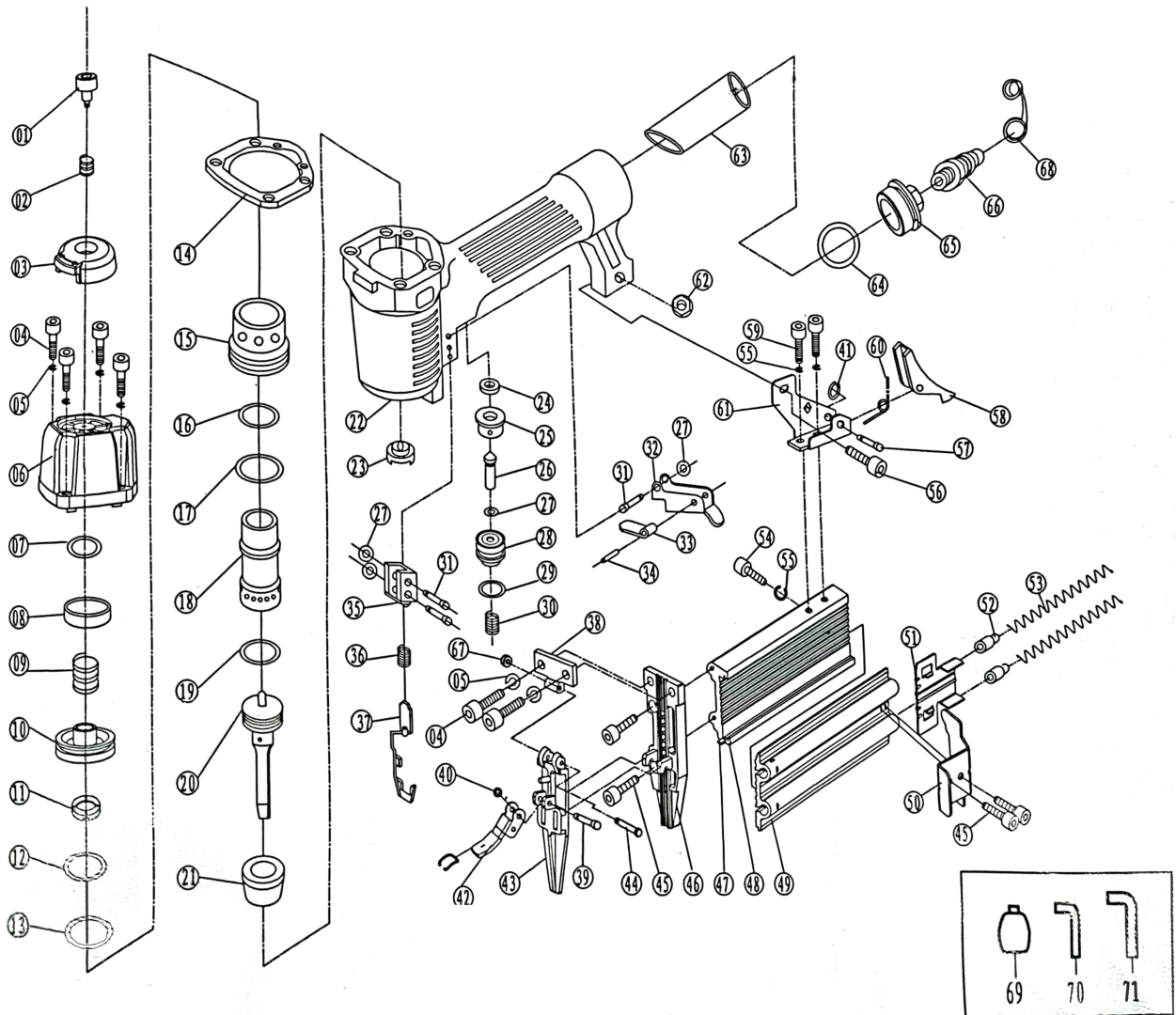

No	Description	No	Description	No	Description	No	Description
1	Screws	22	Gun body	43	Cover plate	64	O-ring 36.3*3.55
2	spring	23	Rubber mat	44	cover pin	65	End cover
3	Air commutator	24	Rectangular seal ring	45	Screw M4 x 14	66	Pipe joint
4	Screw M5*20	25	Valve seat	46	nailhead	67	Pin bush
5	Spring washer 5	26	Valve stem	47	slug	68	
6	Cylinder cap	27	O-ring 1.7*2	48	Fixed magazine	69	oil pot
7	O-ring 13.7*2.4	28	Valve bush	49	Movable magazine	70	Hex key M4/3mm
8	Seal washer	29	O-ring 11.2*2	50	Locating seat	71	Hex key M5/4mm
9	spring	30	spring	51	head	72	
10	Balance valve	31	pin	52	putter	73	
11	Cushion gasket	32	trigger	53	spring	74	
12	O-ring 31.2*2.5	33	Safety damper	54	Screw M4 x7	75	
13	O-ring 24.8*3.5	34	pin 2.5*16	55	Spring washer 4	76	
14	Sealing gasket	35	Slide rack	56	Screw M4 x 20	77	
15	ring	36	spring	57	pin	78	
16	O-ring 26.2*2.4	37	Safety frame assembly	58	Shank of hook	79	
17	O-ring 41.7*3	38	septum	59	Screw M4 x 8	80	
18	cylinder	39	Limit pin	60	Torsion spring	81	
19	O-ring 21.3*3	40	O-ring 1.9*1.2	61	Fixed seat		
20	Piston assembly	41	ring 2.5	62	Nut M4		
21	cushion	42	lever assembly	63	Gun handle sheath		