

## F50 Parts List

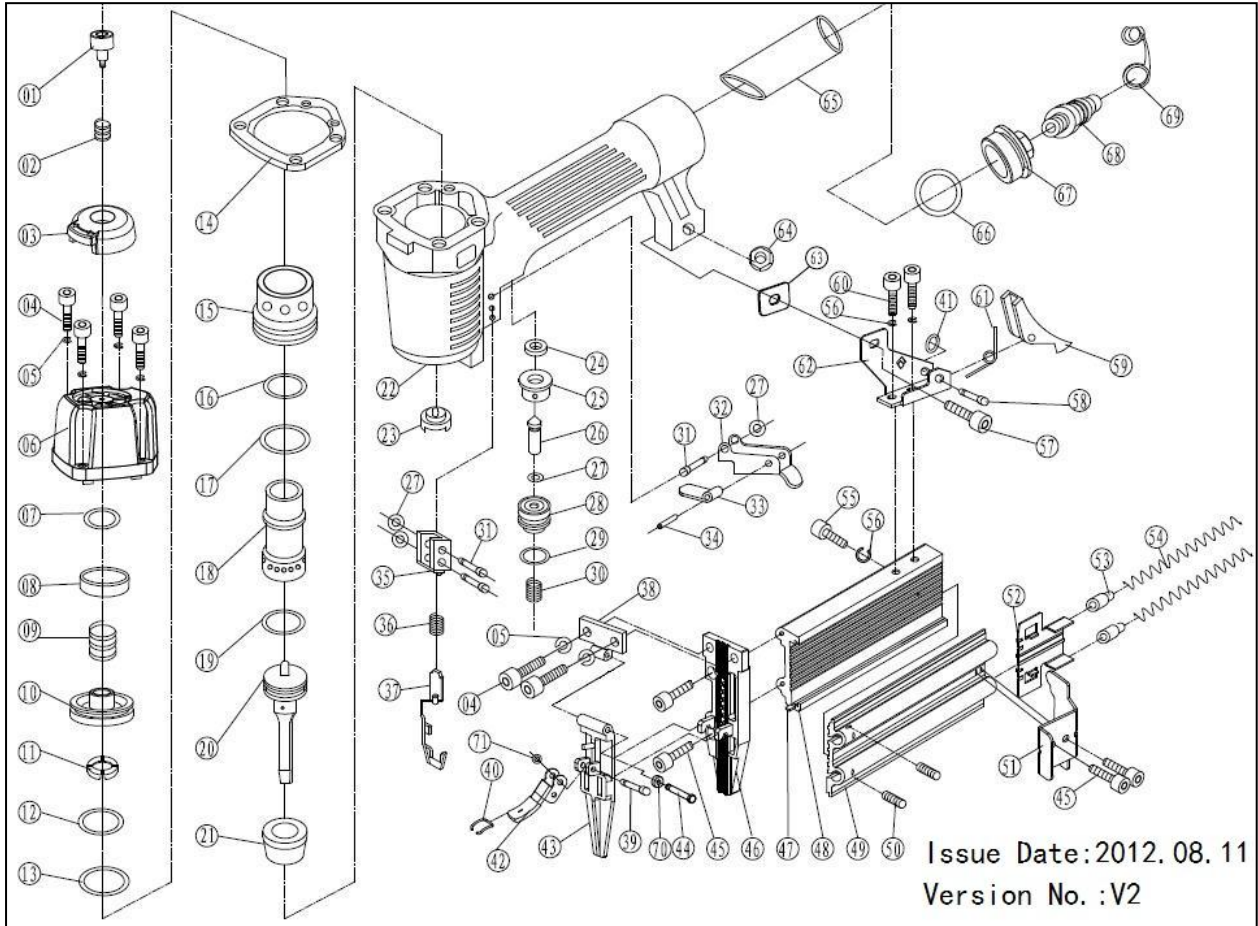

No.	Description	Qty.	No.	Description	Qty.	No.	Description	Qty.
1	Hex bolt	1	25	Valve seat	1	49	Movable magazine	1
2	Air deflector spring	1	26	Valve pin	1	50	Bolt M4*12	2
3	Air deflector	1	27	O-ring 1.7*2	4	51	Fixed seat	1
4	Hex bolt M5*20	6	28	Valve case	1	52	Head piece	1
5	Spring washer	6	29	O-ring 11.2*2	1	53	Head pin	2
6	Cylinder cover	1	30	Compressed spring	1	54	Compressed spring	2
7	O-ring 13.7*2.4	1	31	Shaft pin	3	55	Hex bolt M4*7	1
8	Sealing washer	1	32	Trigger	1	56	Spring washer 4	3
9	Compressed spring	1	33	Safety stand	1	57	Hex bolt M4*20	1
10	Head valve	1	34	Roll pin 2.5*16	1	58	Latch pin	1
11	Bumper washer	1	35	Slip shift	1	59	Latch	1
12	O-ring 31.2*2.5	1	36	Pusher spring	1	60	Hex bolt M4*8	2
13	O-ring 24.8*3.5	1	37	Safety assembly	1	61	Swivel spring	1
14	Sealing washer	1	38	Insulated plate	1	62	Fixed seat	1
15	Collar	1	39	Roll pin	1	63	Washer	1
16	O-ring 30*1.8	1	40	Shrink ring	1	64	Self-lock bolt M4	1
17	O-ring 42.6*2.35	1	41	E-ring 2.5	1	65	Handle case	1
18	Cylinder	1	42	Shrink handle assembly	1	66	O-ring 36.3*3.55	1
19	O-ring 21*3	1	43	Plate	1	67	End cap	1
20	Main piston	1	44	Roll pin A3*18	1	68	Air plug	1
21	Bumper	1	45	Hex bolt M4*14	4	69	Air plug case	1
22	Gun body	1	46	Nose	1	70	Pin case	1
23	Rubber washer	1	47	Slice	1	71	Switch pole O-ring 1.9*1.2	1
24	Rectangle sealing washer	1	48	Fixed magazine	1			